



model motors

High performance electric motors

EVP 2204PROFESSIONAL for 4D flying
Pre-assembled ELECTRIC VARIABLE PITCH PROPELLER



for AXI 2204/54 EVP

- 5 ball bearings
- carbon connecting rod
- optimized propeller blades
- bearing element for easy access
- professional design

Congratulations! Thank you for choosing this product from Model Motors Ltd. This professional Electric Variable Pitch propeller brings you a great opportunity to try a new level of acrobatic flying. Because EVP2204 system is based on a principle of helicopter mechanisms it requires one more micro servo and more setting and programming of your transmitter. Our EVP mechanism is manufactured using precise parts, 5 ball bearings, a carbon connecting rod and an optimized propeller for best performance with a special AXI motor with a Hollow Shaft. This unit is recommended for model airplanes of approximate weight 200g. From parts contained in this package you will assemble an EVP propeller that is designed for AXI 2204/54 EVP.

Safety Warning!

By purchasing EVP Professional, the user (preferably a modeler experienced with acrobatic flight) assumes all responsibility for consequences of its use. Please use extreme caution and never stay close to the space in and around the rotating EVP Professional Propeller. WEAR SAFETY GLASSES!

For using this EVP system you will need following items

- Model Motors AXI EVP Hollow Shaft brushless motor AXI2204/54 EVP
- A light weight micro servo for controlling EVP system, for example HS-55
- 6 channel receiver
- Using specialized transmitters for helicopters is advantageous, because of possible programming of prop pitch and motor RPM influences
- Recommended controller is JETI Advance Plus 8A (without governor)
- High discharge li-poly batteries from 340mAh to 450mAh see the table for suitable set-up
- Airplane with substantial airframe to prevent damage during fast pitch changes

Assembly and installation to model

Final assembly of EVP propeller is easy and intuitive as it is mostly pre-assembled. Before assembly please unscrew or cut carefully the head of 2pcs of screw M2x6. See the picture INSTALLATION OF EVP SYSTEM ABOVE. Screw blade holders to the motor and using thread lock glue for example LOCTITE. Then assemble pitch slider as on the picture and secure propeller blades with screws. Next, set the blades to zero pitch (see picture above) and pull the carbon connecting rod through the hollow shaft to the pitch slider. Set the 7mm distance between the connecting rod and the motor as you see on the picture (zero pitch setting). Then fix the secure ring on the pitch slider and also on the bearing element. Bearing element with set screw is very useful for easy replacing of broken carbon connecting rod. Then cut odd piece of carbon which overflows pitch slider. It is helpful to measure the length of this carbon and make out of 1,5mm diameter carbon spare connecting rods of the same length. Replacing of broken connecting rods is than fast and easy and without need of new setting of EVP! In consequence attach the motor to the airframe and connect the servo with the bearing element as on the picture. It is recommended to adapt airframe to easy servo arm and carbon connecting rod access! The servo arm should be just 7mm long to avoid overloading of servo.

Pitch range of EVP propeller

Key point of successful usage of EVP unite it correct setting of pitch range and flying modes. The pitch movement range of the EVP2204 propeller must be completely free within the entire pitch range. When the zero pitch setting is at 7mm then set maximum negative pitch and maximum positive pitch - see the following picture. For approximate pitch range- see table above. For exact pitch measure current of motor at full RPM and set the max range of the pitch to when you reach the max limiting current - see table above. Example given: max current of AXI 2204/54EVP with 3 lipols is 7A. So set shortly max RPM of the motor and move the max negative and positive pitch in the way to reach max current of the motor 7A. This pitch loads the motor exactly with limiting maximum current. This setting helps to reach good efficiency range of EVP system.

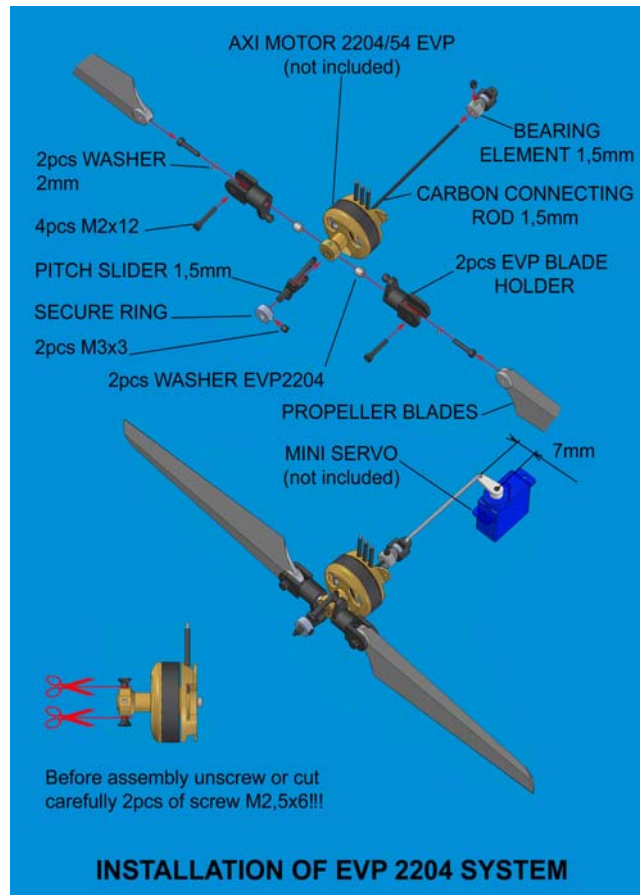

AXI EVP motor	Number of Li-Poly	Controller Jeti Advance plus	Approximate pitch distance in mm			Limit max current in A	Approximate thrust in g	Best model weight in g
			X1-maximal positive	Zero pitch	X2-maximal negative			
2204/54 *	3s 340mAh 20C	8	5	7	9	7	320	180

* be careful not to overload the motor with higher pitch and current than recommended!!!

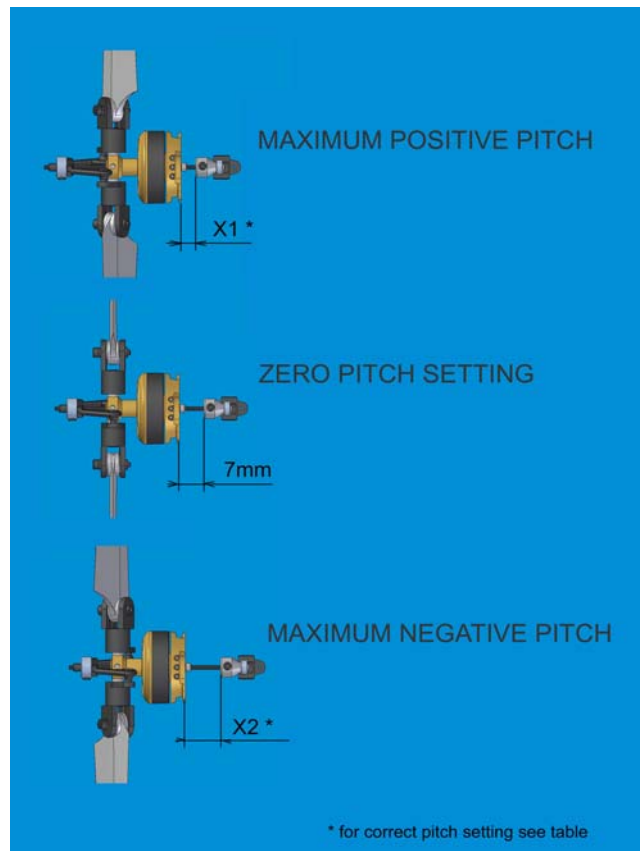

Flying modes with standard controller (for example JETI Advance 8 plus)

Normal mode:

There is set up one angle of variable pitch (only VP) for all throttle positions and as such as where the prop is most effective at lowest current draw. (It's necessary to experiment). So in low throttle the motor is off, and in max throttle position motor is full RPM. So it works like normal motor as you are used to. Usually pitch at normal mode is around 60 percent of max pitch. See picture below.

Idle up mode

Variable pitch is working in full range from minus degrees (negative -100 %) to plus degrees (positive +100 %) and motor is working from half RPM (zero angle of variable pitch 0 %) to full RPM (max. minus and plus angles of variable pitch (see picture above). When setup correctly you should have constant RPM in whole range of pitch.

Setup of transmitter

- In transmitter set program for helicopters in order H1 (heli mechanism with 2 servos)
- Connect controller to the receiver as usual (normal throttle) and servo which control EVP to channel six (PITCH)
- Adjust sense (or REVERSE) and limitation range of pitch servo by ATV and END POINT
- Check if all mixers for helicopter are off (REVO mix, THROTTLE HOVER and PITCH HOVER). If not, deactivate them.
- Find page with THROTTLE CURVE. All points of throttle curve move to zero in both modes (Normal and Idle up 1). This is necessary for basic setup of pitch limitations of VP and also zero pitch of VP. For this is necessary to keep motor **NOT ROTATING** (use external Rx batteries 4.8-6V). **If you will use batteries with higher voltage you will damage receiver and servos.**
- Find page with PITCH CURVE and in mode NORMAL setup one angle of VP. It means that all points of curve must be in line (for example 80%). This is only basic setup, final tuning is made later if necessary. The angle of prop should be around 30°. In this mode is EVP working same as normal prop where you control RPM of motor.
- Stay in same page of PITCH CURVE only switch mode to IDLE UP 1. In this mode set linear curve of servo controlling pitch of variable prop from 0 to 100%. It means if you move throttle stick to low position you will have **max. negative** angle of prop and if you move it to max position you will have **max. positive** angle of prop.
- Find page THROTTLE CURVE and in mode NORMAL set linear curve from 0 to 100%
- Switch to mode IDLE UP 1 and make curve as a letter "V". It means if you have stick in minimum and maximum position there is full throttle. If you have stick in the middle (50%) set throttle to same RPM which you can measure (hear) in max and low angle of VP. For basic settings set it to 20%. Fine-tuning is made during test flights. (For example you change linear curve to three point to make some expo)

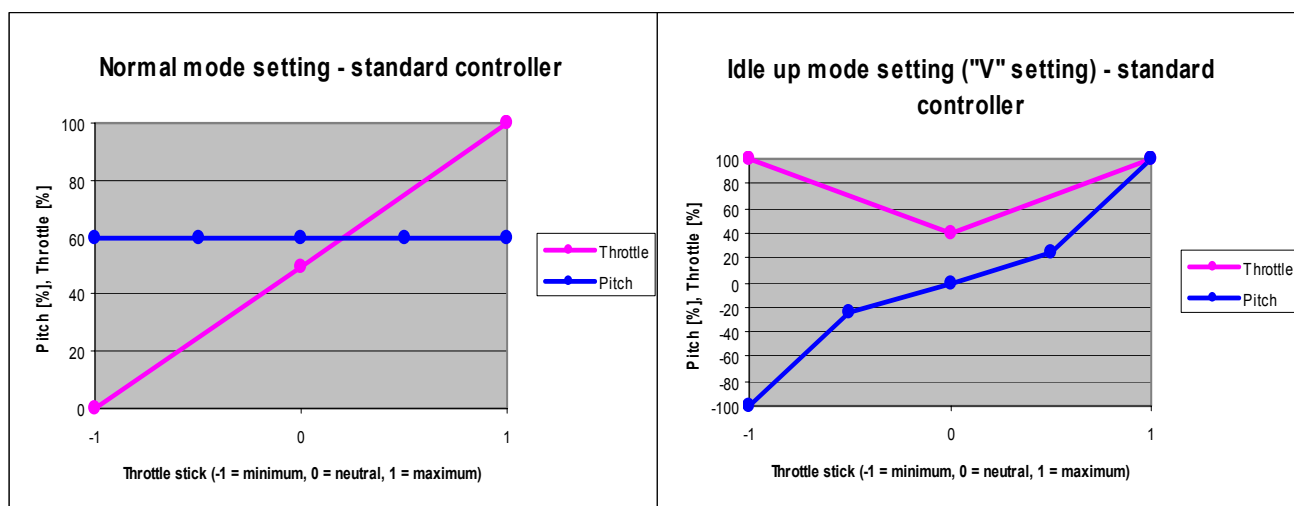

Using EVP Professional

After this setting you can start first tests on the ground where you check if everything is working well without any big vibrations. Now you can check motor to determine if both modes are working correctly.

- Switch NORMAL mode on transmitter and switch on receiver
- Try Normal mode if airplane has enough power for normal flight (if you have high RPM and small static traction or opposite, increase/decrease pitch of prop in page PITCH CURVE, NORMAL mode)
- Now try mode IDLE UP 1
- Move throttle to middle and switch from NORMAL mode to IDLE UP 1
- Try to move with throttle stick forward (you should have enough power for flight) and backwards and you should feel that airplane would like to move backwards quite strongly
- if everything checks OK you can start flying
- For taking off use normal mode and reach some height before you will try IDLE UP 1 mode, because it will take some time before you will feel comfortable with this mode

New maneuvers

Zig-Zag

This is easiest maneuver to learn with new EPV system. Just switch mode IDLE UP 1 and quickly move with throttle stick around middle position. With this maneuver you can learn how the airplane react to negative thrust.

Tight loop

Use mode IDLE UP 1 and fly straight then make tight ¼ of loop and then immediately push full down elevator and use full negative pitch and when airplane is in normal position use half of positive pitch. Repeat this one after another.

Leaf

Climb to a safe altitude and fly straight then use half negative pitch throw. Airplane will start falling down then use full right rudder and down elevator and about half of negative pitch throw. Airplane should start rotate around tail. It most beautiful maneuver which is made possible by EPV.

Inverted torque roll

Climb to a safe altitude and fly straight then use half negative pitch throw. When airplane starts falling down use negative pitch throw as much as need to stop airplane. Use also little bit down elevator.

Use negative pitch throw in all maneuvers like loop, square loop, stall turn in down lines. With EVP you can make this maneuvers with constant speed.

We wish you many new moves and good flight with EVP Professional